



Overview

- [Features, on page 1](#)
- [Deployment Options, on page 4](#)
- [Package Contents, on page 4](#)
- [Serial Number Location, on page 5](#)
- [Front Panel, on page 6](#)
- [Front Panel LEDs, on page 7](#)
- [Rear Panel, on page 8](#)
- [Network Modules, on page 9](#)
- [Hardware Bypass Network Modules, on page 11](#)
- [Power Supply Modules, on page 18](#)
- [Fan Modules, on page 20](#)
- [Supported SFP/SFP+ and QSFP Transceivers, on page 21](#)
- [Hardware Specifications, on page 24](#)
- [Product ID Numbers, on page 26](#)
- [Power Cord Specifications, on page 29](#)

Features

The Cisco Firepower 4100 series security appliance is a standalone modular security services platform. It is capable of running multiple security services simultaneously and so is targeted at the data center as a multiservice platform. The series includes the Firepower 4110, 4120, 4140, and 4150. See [Product ID Numbers, on page 26](#) for a list of the product IDs (PIDs) associated with the 4100 series.

The Firepower 4100 series supports Cisco Firepower Threat Defense, Cisco Firepower eXtensible Operating System (FXOS), and Cisco ASA software. See [Cisco Firepower 4100/9300 FXOS Compatibility](#), which lists software and hardware compatibility information for the Firepower 4100 series.

The Firepower 4100 is certified for the following security standards on ASA 9.8.x and FTD 6.2.x:

- Common Criteria (CC) and Commercial Solutions for Classified (CSFC)
- Federal Information Processing Standards (FIPS)
- Department of Defense Information Network Approved Product List (DoDIN APL)
- US Government Compliance for IPv6 (USGv6)

The Firepower 4100 series is certified for the following security standards on ASA 9.12.x and FTD 6.4.x:

- DoDIN APL

See the "Security Certifications Compliance" chapter in the [Cisco FXOS CLI Configuration Guide](#) or [Cisco FXOS Firepower Chassis Manager Configuration Guide](#) for the procedure to enable security modes.

The following figure shows the Firepower 4100 series security appliance.

Figure 1: Firepower 4100 Series



See the [Cisco Interactive Library](#) for a video that displays the features and components of the Firepower 4100.

The following table lists the features for the Firepower 4100 series.

Table 1: Firepower 4100 Series Features

Feature	4110	4120	4140	4150
Form factor	1 RU Fits a standard 19-in. (48.3cm) square-hole rack			
Rack mount	Yes Slide rails, mount ears, and screws included (4-post EIA-310-D rack)			
Airflow	Front to rear Cold aisle to hot aisle			
Processor	Single 12-core		Single 18-core	Single 22-core
Memory	64-GB DDR4 DRAM	128-GB DDR4 DRAM	256-GB DDR4 DRAM	256-GB DDR4 DRAM
Maximum number of interfaces	24 With two 8-port network modules installed			
Management port	One Gigabit Ethernet Supports 1-Gb fiber or copper SFPs			
Serial port	One RJ-45 console			
USB port	One USB 2.0 Type A			

Feature	4110	4120	4140	4150
Network ports	Eight fixed 1-Gb and 10-Gb SFP ports (named Ethernet 1/1 through 1/8)			
SFP ports	Eight fixed 1-Gb and 10-Gb SFP ports			
Pullout asset card	Displays the serial number; on the front panel			
Grounding lug	On rear panel			
Locator beacon	On front panel			
Power switch	On rear panel			
Network modules	Two network module slots (named network module 2 and network module 3)			
Supported network modules	<ul style="list-style-type: none"> • 8-port 10-Gigabit Ethernet SFP+ • 4-port 40-Gigabit Ethernet QSFP+ • 8-port 1-Gigabit Ethernet copper with hardware bypass • 2-port 40-Gigabit Ethernet QSFP+ (built-in) with hardware bypass • 6-port 1-Gigabit Ethernet SX fiber SFP+ (built-in) with hardware bypass • 6-port 10-Gigabit Ethernet SR fiber SFP+ (built-in) with hardware bypass • 6-port 10-Gigabit Ethernet LR fiber SFP+ (built-in) with hardware bypass 			
AC power supply	Two (1+1) power supply module slots Ships with one 400-W AC power supply modules Hot-swappable		Two (1+1) power supply module slots Ships with two 400-W AC power supply modules Hot-swappable	
DC power supply	No		Yes (optional)	
Redundant power	Yes 1+1			
Fan	Six fan module slots 3+1 redundancy Hot-swappable			
Storage	Two SSD slots (200 GB) Ships with one SSD installed in slot 1. Note RAID is not supported. Slot 2 is reserved for the Malware Storage Pack (MSP).		Two SSD slots (400 GB) Ships with one SSD installed in slot 1. Note RAID is not supported. Slot 2 is reserved for the MSP.	
MSP	Installed in the second SSD slot only			

Deployment Options

Here are some examples of how you can deploy the Firepower 4100:

- In a data center using NGFW and ASA
- At the core/aggregation layer of a 3-tier data center in a high availability configuration
- As a dedicated multifunctional security service within converged infrastructure stacks, for example, vBlock, FlexPod, and so forth, at the access layer
- As a high-performance data center security appliance between the WAN edge and the data center core in a high availability configuration
- Inter-DC clustering deployments
- In newer spine/leaf data center designs, deployment as a leaf that exclusively offers security functions

Package Contents

The following figure shows the package contents for the Firepower 4100. Note that the contents are subject to change and your exact contents might contain additional or fewer items.

Figure 2: Firepower 4100 Package Contents

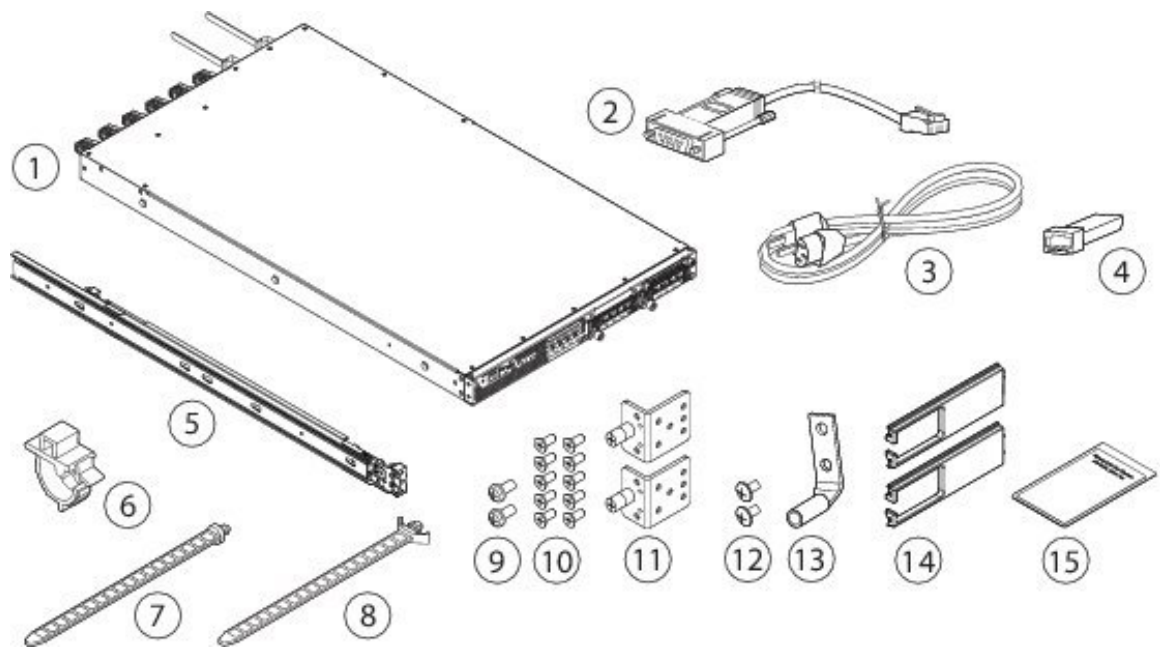

1	Firepower 4100 chassis	2	Blue console cable PC terminal adapter
3	Two power cords (country-specific)	4	10/100/1000BASE-T SFP transceiver
5	Two slide rails	6	Tie wrap clamp

7	Artesyn tie wrap	8	Flextronics tie wrap
9	Two M3X6 mm screws used to secure the inner slide rail to the chassis	10	Ten 8-32 x .375-in. countersink screws used to secure the mounting bracket to chassis (6 screws), and the cable management brackets to the mounting brackets (4 screws)
11	Two slide rail locking brackets	12	Two 10-32 x .375-in. screws used to secure the ground lug
13	One ground lug #6 AWG, 90 degree, #10 post	14	Two cable management brackets
15	Welcome to the Cisco Firepower 4100		

Serial Number Location

The serial number for the Firepower 4100 series chassis is located on the pullout asset card on the front panel.

Figure 3: Serial Number on the 4100 Chassis

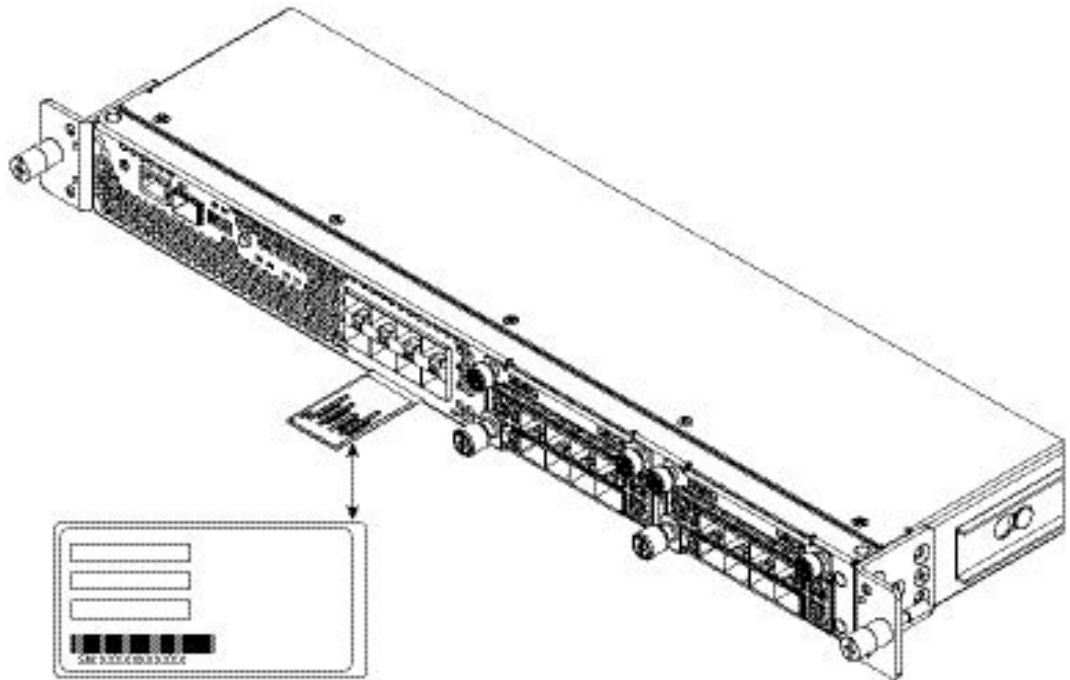

You can also view additional model information on the compliance label located on the bottom of the chassis.

Figure 4: Compliance Label on the 4100 Chassis

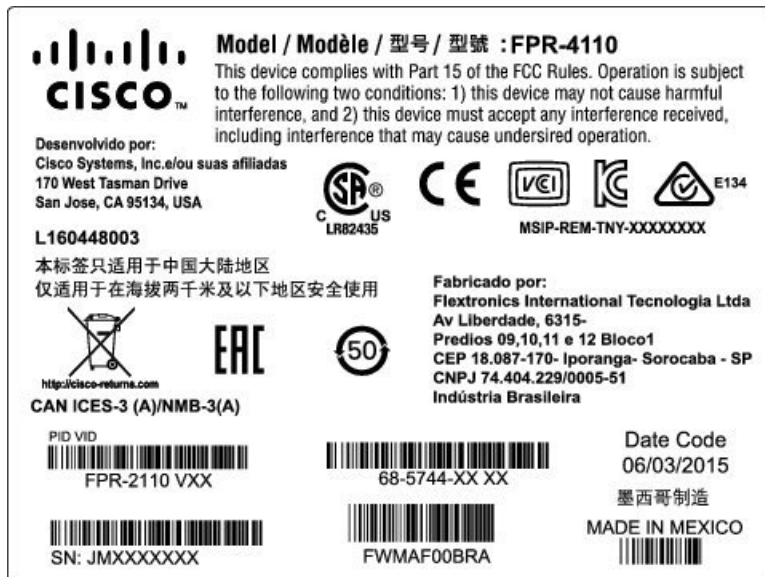

Front Panel

The following figure shows the front panel of the Firepower 4100.

Figure 5: Firepower 4100 Front Panel

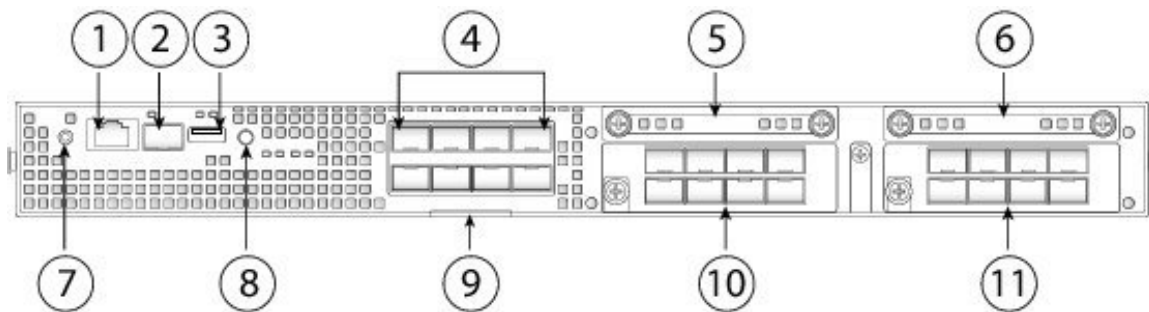

1	RJ-45 console port	2	Gigabit Ethernet management port
3	USB 2.0 Type A port	4	Eight fixed SFP+ (1-Gb/10-Gb) ports (in network module slot 1) Gigabit Ethernet 1/1 through 1/8 labeled top to bottom, left to right
5	SSD 1	6	SSD 2
7	Power LED	8	Locator LED
9	Pullout asset card	10	Network module 2 Note The 10-Gb network module is shown.

11	Network module 3	
	Note The 10-Gb network module is shown.	

Front Panel LEDs

The following figure and table describe the Firepower 4100 front panel LEDs.

Figure 6: Front Panel LEDs

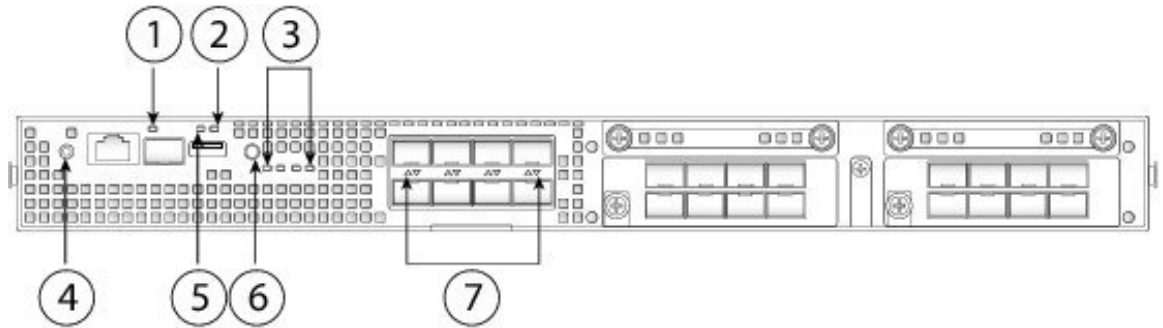

1	Management <ul style="list-style-type: none"> • Off—No connection or port is not in use. • Amber—No link or network failure. • Green—Link up. • Green, flashing—Network activity. 	2	Health (SYS) <ul style="list-style-type: none"> • Off—System is not booting yet. • Green, flashing—Power-up diagnostics are complete and system is booting up. • Green—The system has passed power-up diagnostics. • Amber—Power-up diagnostics has failed. • Amber, flashing—Alarm; power-up diagnostics are running.
3	SSD <ul style="list-style-type: none"> • Off— SSD not present. • Green—SSD is present; no activity. • Green, flashing—SSD is active. • Amber—SSD failure. • Amber, flashing—Rebuilding, flashes at 1 Hz. • Amber, flashing—Predictive failure analysis (PFA) and hot spare; two fast flashes at 4 Hz, pause for 0.5 seconds. 	4	Power <ul style="list-style-type: none"> • Off—Input power not detected. • Green, flashing—Appears only when you move the power switch from ON to OFF. System is shutting down and powers off once shutdown is completed. • Amber—System is powering up. • Green—System fully powered up. • Amber, flashing—Reserved.

5 Active (ACT) This LED is not supported; reserved for future use.	6 Locator LED <ul style="list-style-type: none"> • Off—Locate is off. • Blue—Locate is on.
7 Network activity <ul style="list-style-type: none"> • Off—No connection or port is not in use. • Amber—No link or network failure. • Green—Link up. • Green, flashing—Network activity. 	

Rear Panel

The following figure shows the rear panel of the Firepower 4100.

Figure 7: Firepower 4100 Rear Panel

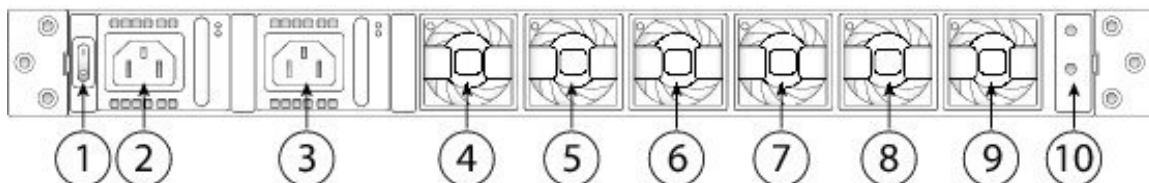

1 Power on/off switch	2 Power supply module 1
3 Power supply module 2	4 Fan module 1
5 Fan module 2	6 Fan module 3
7 Fan module 4	8 Fan module 5
9 Fan module 6	10 Location for the two-post grounding lug Note The two-post grounding lug is included in the accessory kit.

The power switch is located to the left of power supply module 1 on the rear of the chassis. It is a toggle switch that controls power to the system. If the power switch is in standby position, only the 3.3-V standby power is enabled from the power supply module and the 12-V main power is OFF. When the switch is in the ON position, the 12-V main power is turned on and the system boots.

You can shut down the chassis in one of two ways:

- Perform a graceful shutdown using the **shutdown** commands (see the [FXOS CLI Configuration Guide](#) for the procedure). This may take several minutes to complete. Then toggle the power switch to the OFF position. The power LED changes from solid green to off immediately.



Caution If you move the power switch to the OFF position before the **shutdown** command sequence is complete or if you remove the system power cords before the graceful shutdown is complete, disk corruption can occur.

- Toggle the power switch to the OFF position. The power LED changes from solid green to off.



Note After removing power from the chassis either by moving the power switch to OFF or unplugging the power cord, wait at least 10 seconds before turning power back ON.

Network Modules

The Firepower 4100 contains two network module slots that provide optical or electrical network interfaces. Network modules are optional, removable I/O modules that provide either additional ports or different interface types (1/10/40 Gb). The Firepower network modules plug into the chassis on the front panel.

For More Information

- See [10-Gb Network Module, on page 9](#) for a description of the 10-GB network module.
- See [40-Gb Network Module, on page 10](#) for a description of the 40-GB network module.
- See [Hardware Bypass Network Modules, on page 11](#) for the location and description of the LEDs, and the port configurations for the hardware bypass network modules.
- See [Install the Network Module](#) for the procedure for removing and replacing network modules.

10-Gb Network Module

The following figure shows the front panel of the 10-Gb network module (FPR4K-NM-8X10G). The FPR4K-NM-8X10G is a single-wide module that supports hot swapping. The eight ports are numbered from top to bottom, left to right.



Note Make sure you have the correct firmware package and software version installed to support this network module. For instructions on how to verify your firmware package version and to upgrade the firmware if necessary, see the [Cisco Firepower 4100/9300 FXOS Firmware Upgrade Guide](#). See [Cisco Firepower 4100/9300 FXOS Compatibility](#) for the software compatibility matrix.



Note The FPR4K-NM-8X10G is NEBS-compliant.



Note You can fit four copper SFPs in either the top row of ports or the bottom row of ports. Both rows cannot be populated at the same time, because of the port row spacing.

Figure 8: FPR4K-NM-8X10G

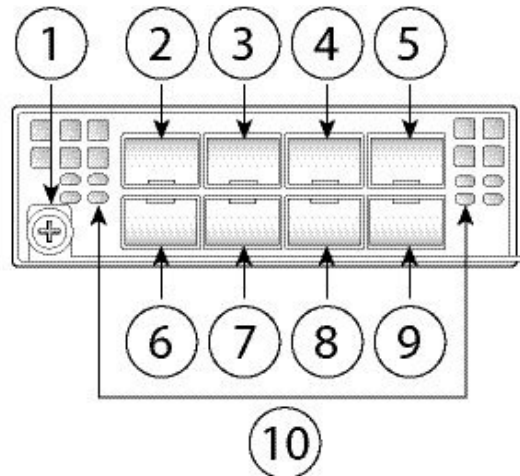

1	Captive screw/handle	2	Ethernet X/1
3	Ethernet X/3	4	Ethernet X/5
5	Ethernet X/7	6	Ethernet X/2
7	Ethernet X/4	8	Ethernet X/6
9	Ethernet X/8	10	Network activity LEDs <ul style="list-style-type: none"> • Off—No connection or port is not in use. • Amber—No link or network failure. • Green—Link up. • Green, flashing—Network activity.

For More Information

- For a list of copper SFPs, see [Supported SFP/SFP+ and QSFP Transceivers, on page 21](#).

40-Gb Network Module

The following figure shows the front panel of the 40-Gb network module (FPR4K-NM-4X40G.) The FPR4K-NM-4X40G is a single-wide module that supports hot swapping. The four ports are numbered left to right.



Note Make sure you have the correct firmware package and software version installed to support this network module. For instructions on how to verify your firmware package version and to upgrade the firmware if necessary, see the [Cisco Firepower 4100/9300 FXOS Firmware Upgrade Guide](#). See [Cisco Firepower 4100/9300 FXOS Compatibility](#) for the software compatibility matrix.



Note The FPR4K-NM-4X40G is NEBS-compliant.

Figure 9: FPR4K-NM-4X40G

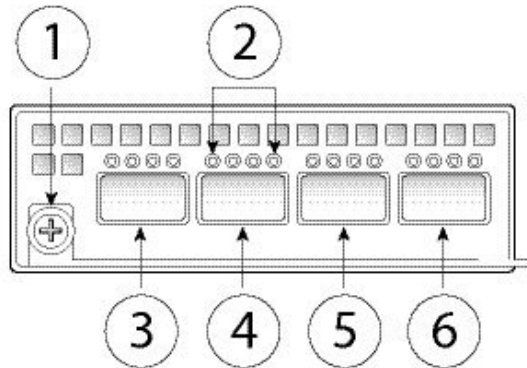

1	Captive screw/handle	2	Network activity LEDs <ul style="list-style-type: none"> • Off—No connection or port is not in use. • Amber—No link or network failure. • Green—Link up. • Green, flashing—Network activity.
3	Ethernet X/1	4	Ethernet X/2
5	Ethernet X/3	6	Ethernet X/4

Hardware Bypass Network Modules

Hardware bypass (also known as fail-to-wire) is a physical layer (Layer 1) bypass that allows paired interfaces to go into bypass mode so that the hardware forwards packets between these port pairs without software intervention. Hardware bypass provides network connectivity when there are software or hardware failures. Hardware bypass is useful on ports where the Firepower security appliance is only monitoring or logging traffic. The hardware bypass network modules have an optical switch that is capable of connecting the two ports when needed. The hardware bypass network modules have built-in SFPs.

Hardware bypass is supported only on a fixed set of ports. You can pair Port 1 with Port 2, Port 3 with Port 4, but you cannot pair Port 1 with Port 4 for example.



Note Hardware bypass is only supported in inline mode. Also, hardware bypass support depends on your software application.



Note When the appliance switches from normal operation to hardware bypass or from hardware bypass back to normal operation, traffic may be interrupted for several seconds. A number of factors can affect the length of the interruption; for example, behavior of the optical link partner such as how it handles link faults and debounce timing; spanning tree protocol convergence; dynamic routing protocol convergence; and so on. During this time, you may experience dropped connections.

There are three configuration options for hardware bypass network modules:

- **Passive interfaces**—Connection to a single port.

For each network segment you want to monitor passively, connect the cables to one interface. This is how the nonhardware bypass network modules operate.

- **Inline interfaces**—Connection to any two like ports (10 Gb to 10 Gb for example) on one network module, across network modules, or fixed ports.

For each network segment you want to monitor inline, connect the cables to pairs of interfaces.

- **Inline with hardware bypass interfaces**—Connection of a hardware bypass paired set.

For each network segment that you want to configure inline with fail-open, connect the cables to the paired interface set.

For the 40-Gb network module, you connect the two ports to form a paired set. For the 1/10-Gb network modules, you connect the top port to the bottom port to form a hardware bypass paired set. This allows traffic to flow even if the security appliance fails or loses power.



Note If you have an inline interface set with a mix of hardware bypass and nonhardware bypass interfaces, you cannot enable hardware bypass on this inline interface set. You can only enable hardware bypass on an inline interface set if all the pairs in the inline set are valid hardware bypass pairs.

For More Information

- See [1-Gb Network Module with Hardware Bypass, on page 13](#) for a description of the 1-Gb network module.
- See [40-Gb Network Module with Hardware Bypass, on page 14](#) for a description of the 40-Gb network module.
- See [1-Gb SX/10-Gb SR/10-Gb LR Network Module with Hardware Bypass, on page 15](#) for a description of the 1-Gb SX, 10-Gb SR and LR network modules.
- See [Install the Network Module](#) for the procedure for removing and replacing single-wide network modules.

1-Gb Network Module with Hardware Bypass

The following figure shows the front panel view of the 1-Gb network module with hardware bypass (FPR4K-NM-8X1G-F). Pair ports 1 and 2, 3 and 4, 5 and 6, and 7 and 8 to form hardware bypass paired sets.



Note Make sure you have the correct firmware package and software version installed to support this network module. For instructions on how to verify your firmware package version and to upgrade the firmware if necessary, see the [Cisco Firepower 4100/9300 FXOS Firmware Upgrade Guide](#). See [Cisco Firepower 4100/9300 FXOS Compatibility](#) for the software compatibility matrix.

Figure 10: FPR-NM-8X1G-F

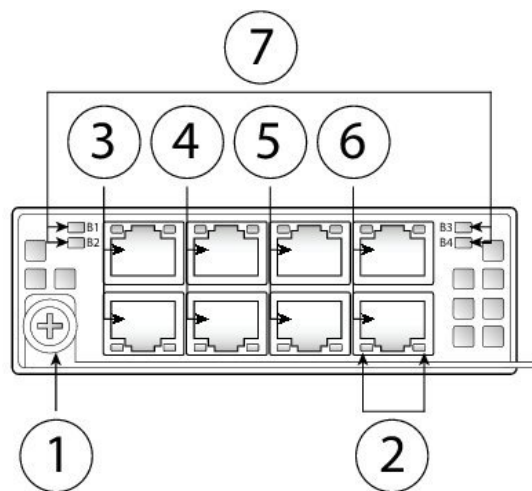

1	Captive screw/handle	2	8 network activity LEDs
		<ul style="list-style-type: none"> • Left LED—Green indicates network activity when a 10M/100M/1G connection is made. • Right LED—Not in use at this time. 	
3	Ethernet X/1 Ports 1 and 2 are paired together to form a hardware bypass pair. LED B1 applies to this paired port.	4	Ethernet X/2 Ports 3 and 4 are paired together to form a hardware bypass pair. LED B2 applies to this paired port.
5	Ethernet X/2 Ports 5 and 6 are paired together to form a hardware bypass pair. LED B3 applies to this paired port.	6	Ethernet X/2 Ports 7 and 8 are paired together to form a hardware bypass pair. LED B4 applies to this paired port.

7	Bypass LEDs B1 through B4 <ul style="list-style-type: none"> • Green—In standby mode. • Amber, flashing—Port is in hardware bypass mode, failure event. • Amber—Port is in hardware bypass mode, forced. 	
----------	---	--

40-Gb Network Module with Hardware Bypass

The following figure shows the front panel of the 40-Gb hardware bypass network module (FPR4K-NM-2X40G-F). The FPR4K-NM-2X40G-F is a single-wide module that does *not* support hot swapping. The two ports are numbered left to right. Pair the two ports to create a hardware bypass paired set.



Note Make sure you have the correct firmware package and software version installed to support this network module. For instructions on how to verify your firmware package version and to upgrade the firmware if necessary, see the [Cisco Firepower 4100/9300 FXOS Firmware Upgrade Guide](#). See [Cisco Firepower 4100/9300 FXOS Compatibility](#) for the software compatibility matrix.

Figure 11: FPR4K-NM-2X40G-F

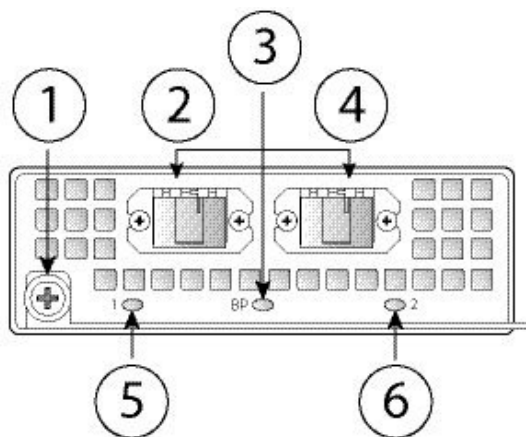

1	Captive screw/handle	
2	Ethernet X/1	Ports 1 and 2 are paired together to form a hardware bypass pair.

3	Bypass LED BP: <ul style="list-style-type: none"> • Green—In standby mode. • Amber, flashing—Port is in hardware bypass mode, failure event. • Amber—Port is in hardware bypass mode, forced. 	4	Ethernet X/2 Ports 1 and 2 are paired together to form a hardware bypass pair.
5	Network activity LEDs for Pair 1: <ul style="list-style-type: none"> • Amber—No connection, or port is not in use, or no link or network failure. • Green—Link up, no network activity. • Green, flashing—Network activity. 	6	Network activity LEDs for Pair 2: <ul style="list-style-type: none"> • Amber—No connection, or port is not in use, or no link or network failure. • Green—Link up, no network activity. • Green, flashing—Network activity.

The following table describes the cable specifications needed to keep the insertion loss as low as possible.

Table 2: 40-Gb BASE-SR Cable Specifications

Interface	Supported Cable
Ethernet 40-G BASE-SR4	50 microns core diameter
850 nm wavelength	2000/4700 (OM3/4) modal bandwidth (MHz*km)
MPO-12 port adapter	50 m cable distance



Note See the [Cisco 40GBASE QSFP Modules Data Sheet](#) for specifications of the QSFP for the 40-Gb BASE-SR-4.

We recommend the following Cisco OM3 MTP/MPO cables.

Table 3: Cisco Cables

Cisco Part Number	Cable Length
CAB-ETH-40G-5M	5 m
CAB-ETH-40G-10M	10 m
CAB-ETH-40G-20M	20 m

1-Gb SX/10-Gb SR/10-Gb LR Network Module with Hardware Bypass

The following figure shows the front panel of the 1-Gb SX, 10-Gb SR and 10-Gb LR hardware bypass network modules (FPR4K-NM-6X1SX-F, FPR4K-NM-6X10SR-F, FPR4K-NM-6X10LR-F). This is a single-wide module that does *not* support hot swapping. The six ports are numbered from top to bottom, left to right. Pair ports 1 and 2, 3 and 4, and 5 and 6 to form hardware bypass paired sets.



Note Make sure you have the correct firmware package and software version installed to support this network module. For instructions on how to verify your firmware package version and to upgrade the firmware if necessary, see the [Cisco Firepower 4100/9300 FXOS Firmware Upgrade Guide](#). See [Cisco Firepower 4100/9300 FXOS Compatibility](#) for the software compatibility matrix.

Figure 12: FPR4K-NM-6X1SX-F, FPR4K-NM-6X10SR-F, FPR4K-NM-6X10LR-F

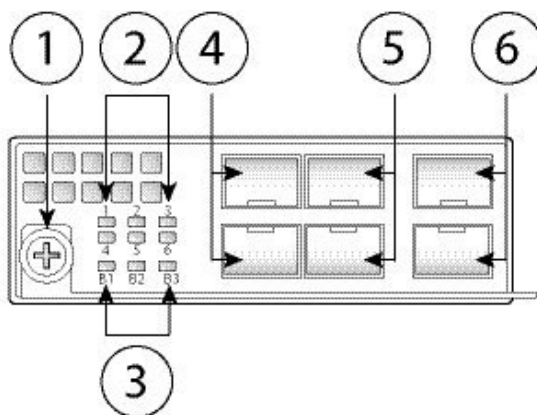

<p>1 Captive screw/handle</p>	<p>2 Six network activity LEDs</p> <ul style="list-style-type: none"> • Amber—No connection, or port is not in use, or no link or network failure. • Green—Link up, no network activity. • Green, flashing—Network activity.
<p>3 Bypass LEDs B1 through B3:</p> <ul style="list-style-type: none"> • Green—In standby mode. • Amber, flashing—Port is in hardware bypass mode, failure event. • Amber—Port is in hardware bypass mode, forced. 	<p>4 Ethernet X/1 (top port) Ethernet X/2 (bottom port)</p> <p>Ports 1 and 2 are paired together to form a hardware bypass pair.</p>
<p>5 Ethernet X/3 (top port) Ethernet X/4 (bottom port)</p> <p>Ports 3 and 4 are paired together to form a hardware bypass pair.</p>	<p>6 Ethernet X/5 (top port) Ethernet X/6 (bottom port)</p> <p>Ports 5 and 6 are paired together to form a hardware bypass pair.</p>

The 1-Gb SX /10-Gb SR/10-Gb LR network modules have the following insertion loss measurements. Insertion loss measurements help you to troubleshoot the network by verifying cable installation and performance.

Table 4: 1-Gb SX Network Module (FPR4K-NM-6X1SX-F)

	Operating Mode	Typical	Maximum
Insertion loss	Normal	0.9 dB	1.4 dB
	Hardware bypass	1.2 dB	1.7 dB
	Core diameter (microns)	Modal bandwidth (MHz/km)	Cable distance Note Half the distance specified by the IEEE standard.
Cable and operating distance	62.5	160 (FDDI)	110 m
	62.5	200 (OM1)	137 m
	50	400	250 m
	50	500 (OM2)	275 m
	50	2000 (OM3)	500 m

Table 5: 10-Gb SR Network Module (FPR4K-NM-6X10SR-F)

	Operating Mode	Typical	Maximum
Insertion loss	Normal	0.9 dB	1.4 dB
	Hardware bypass	1.2 dB	1.7 dB
	Core diameter (microns)	Modal bandwidth (MHz/km)	Cable distance Note Half the distance specified by the IEEE standard.
Cable and operating distance	62.5	160 (FDDI)	13 m
	62.5	200 (OM1)	16.5 m
	50	400	33 m
	50	500 (OM2)	41 m
	50	2000 (OM3)	150 m
	50	4700 (OM4)	200 m

Table 6: 10-Gb LR Network Module (FPR4K-NM-6X10LR-F)

	Operating Mode	Typical	Maximum
--	----------------	---------	---------

Insertion loss	Normal	1.2 dB	1.6 dB
	Hardware bypass	1.5 dB	1.9 dB
	Core diameter (microns)	Modal bandwidth (MHz/km)	Cable distance Note Half the distance specified by the IEEE standard.
Cable and operating distance	G.652	Single mode	5 km

Power Supply Modules

The Firepower 4100 supports two AC or DC power supply modules so that dual power supply redundancy protection is available. Facing the back of the chassis, the power supply modules are numbered left to right, for example, PSU1 and PSU2.



Note Do not mix AC and DC power supply modules in one chassis.



Note After removing power from the chassis either by moving the power switch to OFF or unplugging the power cord, wait at least 10 seconds before turning power back ON.



Attention Make sure that one power supply module is always active.

See [Remove and Replace the Power Supply Module](#) for the procedure for removing and replacing the power supply module.

AC Power Supply

The power supplies can supply up to 1100-W power across the input voltage range. The load is shared when both power supply modules are plugged in and running at the same time. The power supply modules are hot-swappable.

Table 7: AC Power Supply Module Hardware Specifications

Description	Specification
Input voltage	100 to 240 V AC

Maximum current	13 A (at 100 V AC) Note The system power requirements are lower than the power supply module capabilities. See Hardware Specifications, on page 24 for the system power requirements.
Maximum output power	1100 W
Frequency	50 to 60 Hz
Redundancy	1+1 redundant
Efficiency at 50% load	92%

DC Power Supply

The power supplies can supply up to 950 W of power across the input voltage range. The load is shared when both power supply modules are plugged in and running at the same time. The power supply modules are hot-swappable.

Table 8: DC Power Supply Module Hardware Specifications

Description	Specification
Input voltage	-40 to -60 V DC
Maximum current	26A (at 40 V DC) Note The system power requirements are lower than the power supply module capabilities. See Hardware Specifications, on page 24 for the system power requirements.
Maximum output power	950 W
Redundancy	1+1 redundant
Efficiency at 50% load	92%

Power Supply Module LEDs

The following figure shows the two-color power supply LEDs. The LEDs are located on the upper right side.

Figure 13: Power Supply Module LEDs

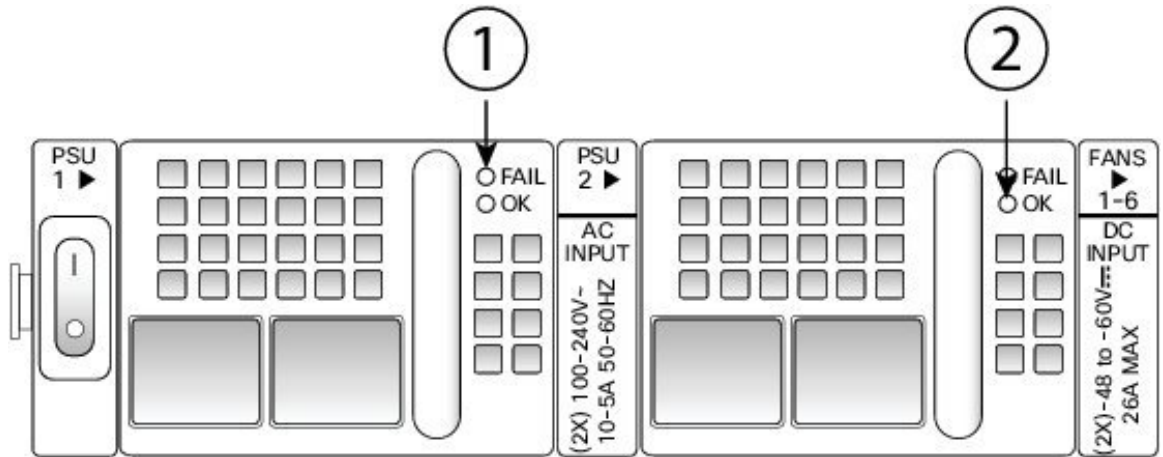

1	Amber FAIL LED	2	Green OK LED
----------	----------------	----------	--------------

The following table describes the power module supply LEDs and their states.

Table 9: Power Supply Module LEDs

	Amber LED (Fail Status)	Green LED (OK Status)
No power to all power supplies	Off	Off
Power supply module failure Includes overvoltage, overcurrent, overtemperature, and fan failure	On	Off
Power supply module warning events Power supply continues to operate. With high temperature, high power, and slow fan	1 Hz flashing	Off
Power is present. 3.3 VSB on (power supply module off)	Off	1 Hz flashing
Power supply module is OK and on.	Off	On

Fan Modules

The Firepower 4100 requires six fan modules, which are hot-swappable. They are installed in the rear of the chassis. The system supports operation with a single fan failure (N+1 fan redundancy), but do not run the system for an extended amount of time without all fan modules installed. Keep removal and replacement time at three minutes. Remove and replace one fan module at a time.

If you remove a fan or a fan fails, the other fans operate at full speed, which can be noisy.

The fan modules are numbered left to right, for example, FAN1, FAN2, FAN3, FAN4, FAN5, and FAN6. See [Remove and Replace the Fan Module](#) for the procedure for removing and replacing the fan module.

The following figure shows the location of the fan LED.

Figure 14: Fan LED

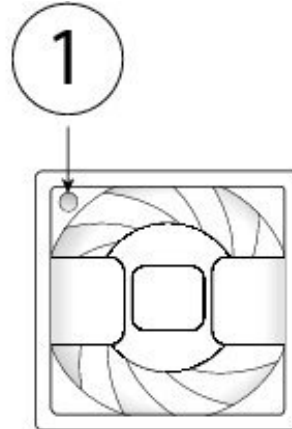

1	Two-color LED
----------	---------------

The fan module has one two-color LED, which is located on the upper left corner of the fan.

- Amber—Fan failure.
- Green—Fan running normally. It may take up to one minute for the LED status to turn green after power is on.

Supported SFP/SFP+ and QSFP Transceivers

The SFP/SFP+ transceivers are bidirectional devices with a transmitter and receiver in the same physical package. It is a hot-swappable optical or electrical (copper) interface that plugs into the SFP/SFP+ ports on the fixed ports and the network module ports, and provides Ethernet connectivity.



Warning

Use appropriate ESD procedures when inserting the transceiver. Avoid touching the contacts at the rear, and keep the contacts and ports free of dust and dirt. Keep unused transceivers in the ESD packing that they were shipped in. The following figure shows a sample SFP transceiver.

Figure 15: SFP

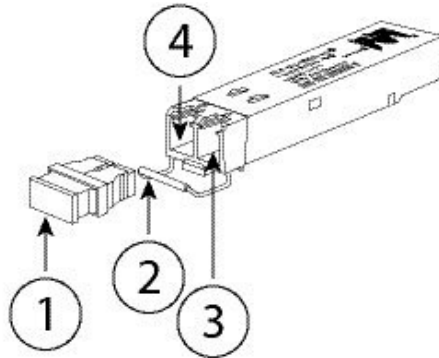

1	Dust plug	2	Bail clasp
3	Receive optical bore	4	Transmit optical bore

**Caution**

For some earlier production Firepower 4100 chassis, you may experience difficulty using the GLC-TE SFP on the management port or fixed ports. Contact Cisco TAC for support if you encounter problems with the GLC-TE SFP.

The following table lists the Cisco supported transceivers.

Table 10: Supported Cisco SFP/SFP+ Transceivers

Optics Type	PID
1 Gb	
1G-SX	GLC-SX-MMD
1G-LH/LX	GLC-LH-SMD
1G-EX	GLC-EX-SMD
1G-ZX	GLC-ZX-SMD
1G 1000Base-T	GLC-T
1G 1000Base-T	GLC-TE
10 Gb	
10G-SR	SFP-10G-SR
10G-SR-S	SFP-10G-SR-S
10G-LR	SFP-10G-LR
10G-LR-S	SFP-10G-LR-S

10G-LRM	SFP-10G-LRM
10G-ER	SFP-10G-ER
10G-ER-S	SFP-10G-ER-S
10G-ZR-S	SFP-10G-ZR-S
10G Cu, 1m	SFP-H10GB-CU1M
10G Cu, 1.5m	SFP-H10GB-CU1-5M
10G Cu, 2m	SFP-H10GB-CU2M
10G Cu, 2.5m	SFP-H10GB-CU2-5M
10G Cu, 3m	SFP-H10GB-CU3M
10G Cu, 5m	SFP-H10GB-CU5M
10G Cu, 7m	SFP-H10GB-ACU7M
10G Cu, 10m	SFP-H10GB-ACU10M
10G AOC, 1m	SFP-10G-AOC1M
10G AOC, 2m	SFP-10G-AOC2M
10G AOC, 3m	SFP-10G-AOC3M
10G AOC, 5m	SFP-10G-AOC5M
10G AOC, 7m	SFP-10G-AOC7M
10G AOC, 10m	SFP-10GAOC10M
40 Gb	
40G-SR4	QSFP-40G-SR4
40G-SR4-S	QSFP-40G-SR4-S
40G-CSR4	QSFP-40G-CSR4
40G-SR-BD	QSFP-40G-SR-BD
40GE-LR4	QSFP-40GE-LR4
40GE-LR4-S	QSFP-40GE-LR4-S
40G-LR4L	WSP-Q40GLR4L
40G-CU, 1M, 3M, 5M	QSFP-H40G-CU
40G-4X10G-CU, 1M, 3M, 5M	QSFP-4SFP10G-CU
40G-CU-A, 7M, 10M	QSFP-H40G-ACU

40G-4X10G-CU-A, 7M, 10M	QSFP-4X10G-AC
40G-AOC, 1M, 2M, 3M, 5M, 7M, 10M, 15M	QSFP-H40G-AOC

Hardware Specifications

The following table contains hardware specifications for the Firepower 4100.

Table 11: Firepower 4100 Hardware Specifications

Specification	4110	4120	4140	4150
Physical				
Form factor	1 RU Fits standard 19-in. (48.3-cm) square-hole rack			
Rack mount	Mount rails included 4-post EIA-310-D rack			
Dimensions (H x W x D)	1.75 x 16.89 x 29.7 in. (4.44 x 42.90 x 75.43 cm) 1.75 x 16.89 x 31.52 in. (4.44 x 42.90 x 80.06 cm) with fans			
Weight	36 lb (16kg) two power supply modules, two network modules, 6six fans 30 lb (13.6 kg) no power supply modules, no network modules, no fans			
Storage				
SSD	100 GB Note The storage SSD must be installed in slot 1. Slot 2 is reserved for the MSP SSD. Note If you are running Firepower Threat Defense software, we recommend that you upgrade to the latest version (at least to Version 6.1.0) to take advantage of software updates that enhance SSD management performance and longevity.		200 GB Note The storage SSD must be installed in slot 1. Slot 2 is reserved for the MSP SSD. Note If you are running Firepower Threat Defense software, we recommend that you upgrade to the latest version (at least to Version 6.1.0) to take advantage of software updates that enhance SSD management performance and longevity.	
MSP	800 GB Note The MSP SSD must be installed in slot 2.			
Memory				
DDR4 DIMM	64 GB	128 GB	256 GB	

Specification	4110	4120	4140	4150
Power				
System power	AC: 100/240 V AC 10 A (at 100 V), 50 to 60 Hz DC: -40 V DC to -60 V DC, 26 A (at -40 V)			
Power supply module	AC or DC			
Redundant power	Yes			
Environment				
Temperature	Operating: 32 to 104° F (0 to 40° C) Nonoperating: -40 to 149°F (-40 to 65° C)		Operating: 32 to 95° F (0 to 35° C) at sea level 1° C reduction of maximum for every 1000 ft (305 m) above sea level Nonoperating: -40 to 149° F (-40 to 65° C)	
Humidity	Operating and nonoperating: 5 to 95% noncondensing			
Altitude	Operating: 10,000 ft maximum (3048 m) Nonoperating: 40,000 ft maximum (12,192 m)			
Acoustic noise	Sound pressure: <ul style="list-style-type: none"> • 66 dBA (typical) • 78 dBA (maximum) Sound power: <ul style="list-style-type: none"> • 76 dBA (typical) • 88 dBA (maximum) 			
Air flow	Front to back			

Specification	4110	4120	4140	4150
NEBS operation	—			Operating temperature: <ul style="list-style-type: none"> • Long term: 0 to 45° C up to 6000 ft (1829 m) • Long term: 0 to 35° C up to 6000-13,000 ft (1829-3964 m) • Short term: -5 to 55° C up to 6000 ft (1829 m) Operating altitude: 0 to 13,000 ft (3962 m)

Product ID Numbers

The following table lists the PIDs associated with the Firepower 4100 series. All of the PIDs in the table are field-replaceable. See the **show inventory** command in the [Cisco Firepower 4100/9300 FXOS Command Reference](#), in the [Cisco Firepower Threat Defense Command Reference](#), or in the [Cisco ASA Series Command Reference](#) for the procedure to display a list of the PIDs for your Firepower 4100.

Table 12: Firepower 4100 Series PIDs

PID	Description
FPR4110-AMP-K9	Cisco Firepower 4110 AMP appliance, 1 RU, two network module bays
FPR4110-ASA-K9	Cisco Firepower 4110 ASA appliance, 1 RU, two network module bays
FPR4110-NGFW-K9	Cisco Firepower 4110 NGFW appliance, 1 RU, two network module bays
FPR4110-NGIPS-K9	Cisco Firepower 4110 NGIPS appliance, 1 RU, two network module bays
FPR4120-AMP-K9	Cisco Firepower 4120 AMP appliance, 1 RU, two network module bays
FPR4120-ASA-K9	Cisco Firepower 4120 ASA appliance, 1 RU, two network module bays

PID	Description
FPR4120-NGFW-K9	Cisco Firepower 4120 NGFW appliance, 1 RU, two network module bays
FPR4120-NGIPS-K9	Cisco Firepower 4120 NGIPS appliance, 1 RU, two network module bays
FPR4140-AMP-K9	Cisco Firepower 4140 AMP appliance, 1 RU, two network module bays
FPR4140-ASA-K9	Cisco Firepower 4140 ASA appliance, 1 RU, two network module bays
FPR4140-NGFW-K9	Cisco Firepower 4140 NGFW appliance, 1 RU, two network module bays
FPR4140-NGIPS-K9	Cisco Firepower 4140 NGIPS appliance, 1 RU, two network module bays
FPR4150-AMP-K9	Cisco Firepower 4150 AMP appliance, 1 RU, two network module bays
FPR4150-ASA-K9	Cisco Firepower 4150 ASA appliance, 1 RU, two network module bays
FPR4150-NGFW-K9	Cisco Firepower 4150 NGFW appliance, 1 RU, two network module bays
FPR4150-NGIPS-K9	Cisco Firepower 4150 NGIPS appliance, 1 RU, two network module bays
FPR4K-ACC-KIT	Firepower hardware accessory kit containing rack mounts and cables
FPR4K-ACC-KIT=	Firepower hardware accessory kit containing rack mounts and cables (spare)
FPR4K-ASA-CAR	License to add carrier security to ASA on the Firepower 4100
FPR4K-FAN	Fan
FPR4K-FAN=	Fan (spare)
FPR4K-NM-2X40G-F	2-port 40-Gb SR hardware bypass network module
FPR4K-NM-2X40G-F=	2-port 40-Gb SR hardware bypass network module (spare)
FPR4K-NM-4X40G	4-port 40-Gb QSFP+ network module
FPR4K-NM-4X40G=	4-port 40-Gb QSFP+ network module (spare)
FPR4K-NM-6X10LR-F	6-port 10-Gb LR hardware bypass network module

PID	Description
FPR4K-NM-6X10LR-F=	6-port 10-Gb LR hardware bypass network module (spare)
FPR4K-NM-6X10SR-F	6-port 10-Gb SR hardware bypass network module
FPR4K-NM-6X10SR-F=	6-port 10-Gb SR hardware bypass network module (spare)
FPR4K-NM-6X1SX-F	6-port 1-Gb SX fiber hardware bypass network module
FPR4K-NM-6X1SX-F=	6-port 1-Gb SX fiber hardware bypass network module (spare)
FPR4K-NM-8X10G	8-port 10-Gb SFP+ network module
FPR4K-NM-8X10G=	8-port 10-Gb SFP+ network module (spare)
FPR4K-NM-8X1G-F	8-port 1-Gb copper hardware bypass network module
FPR4K-NM-8X1G-F=	8-port 1-Gb copper hardware bypass network module (spare)
FPR4K-NM-BLANK	Network module blank slot cover
FPR4K-NM-BLANK=	Network module blank slot cover (spare)
FPR4K-PSU-BLANK	Chassis power supply module blank slot cover
FPR4K-PSU-BLANK=	Chassis power supply module blank slot cover (spare)
FPR4K-PWR-AC-1100	1100W AC power supply module
FPR4K-PWR-AC-1100-	1100W AC power supply module (spare)
FPR4K-PWR-DC-950	950W DC power supply module
FPR4K-PWR-DC-950=	950W DC power supply module (spare)
FPR4K-RACK-MNT	Rack mount kit
FPR4K-RACK-MNT=	Rack mount kit (spare)
FPR4K-SSD-BBLKD	SSD slot carrier
FPR4K-SSD-BBLKD=	SSD slot carrier (spare)
FPR4K-SSD200	200-GB SSD for Firepower 4110 and 4120
FPR4K-SSD200=	200-GB SSD for Firepower 4110 and 4120 (spare)
FPR4K-SSD400	400-GB SSD for Firepower 4140 and 4150
FPR4K-SSD400=	400-GB SSD for Firepower 4140 and 4150 (spare)

Power Cord Specifications

Each power supply has a separate power cord. Standard power cords are available for connection to the security appliance.

If you do not order the optional power cord with the system, you are responsible for selecting the appropriate power cord for the product. Using a incompatible power cord with this product may result in electrical safety hazard. Orders delivered to Argentina, Brazil, and Japan must have the appropriate power cord ordered with the system.



Note Only the approved power cords or jumper power cords provided with the security appliance are supported.

The following power cords are supported.

Figure 16: Argentina CAB-9K10A-AR

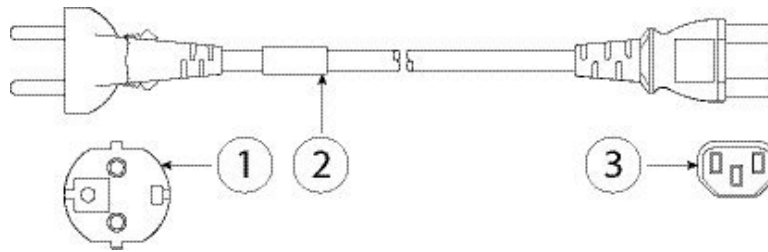

1	Plug: IRAM 2073	2	Cord set rating: 10 A, 250 V
3	Connector: IEC 60320-C15		

Figure 17: Australia CAB-9K10A-AU

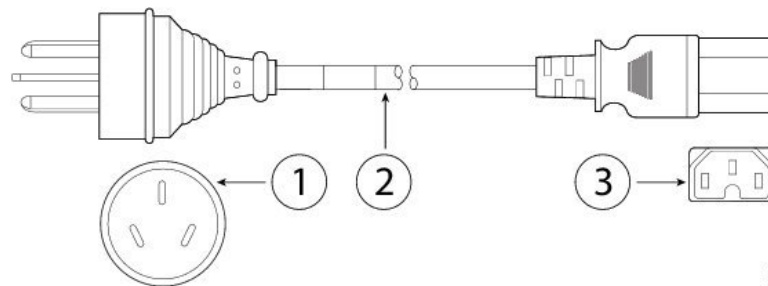

1	Plug: A.S. 3112-2000	2	Cord set rating: 10 A, 250 V
3	Connector: IEC 60320-C15		

Figure 18: Brazil CAB-250V-10A-BR

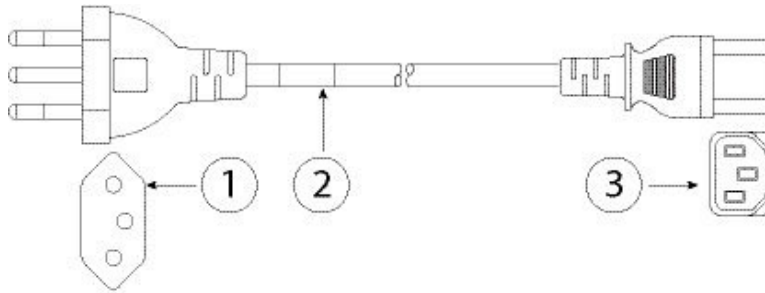

1	Plug: EL223 (NBR 14136)	2	Cord set rating: 10 A, 250 V
3	Connector: EL 701B (EN 60320/C13)		

Figure 19: Brazil PWR-CORD-G2A-BZ

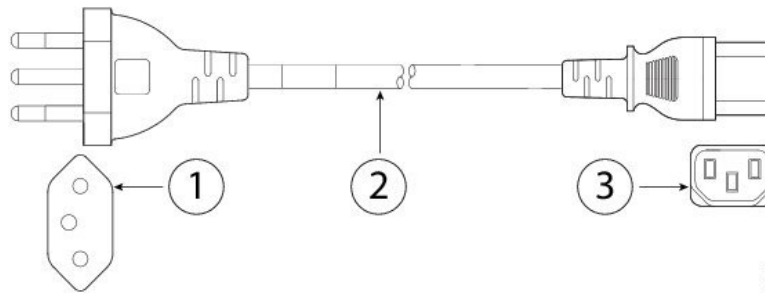

1	Plug: NBR 14136	2	Cord set rating: 10 A, 250 V
3	Connector: IEC 60320-C13		

Figure 20: China CAB-9K10A-CH

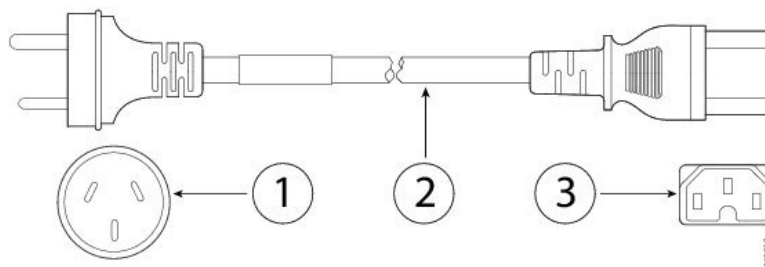

1	Plug: CCC GB2099.1, GB1002	2	Cord set rating: 10 A, 250 V
3	Connector: IEC 60320-C15		

Figure 21: Denmark CAB-TA-DN

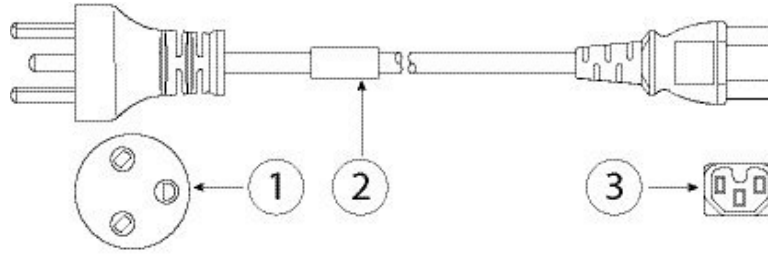

1	Plug: DK3	2	Cord set rating: 10 A, 250 V
3	Connector: IEC 60320-C13		

Figure 22: Europe CAB-AC-EUR

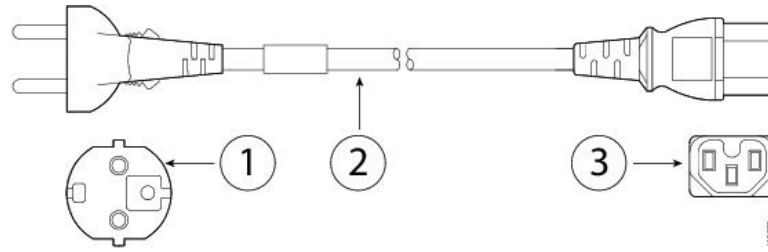

1	Plug: CEE 7/7	2	Cord set rating: 10 A, 250 V
3	Connector: IEC 60320-C15		

Figure 23: India CAB-250V-10A-ID

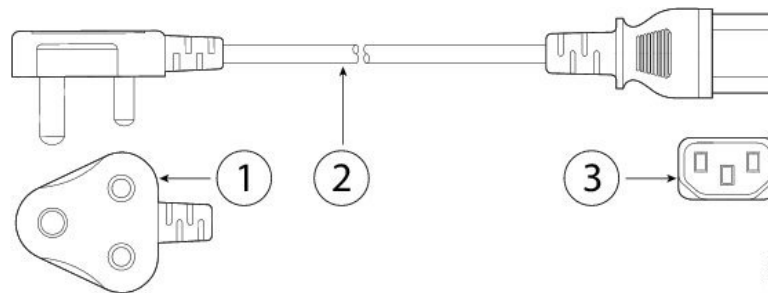

1	Plug: IS 6538-1971	2	Cord set rating: 10 A, 250 V
3	Connector: IEC 60320-C13		

Figure 24: Israel CAB-250V-10A-IS

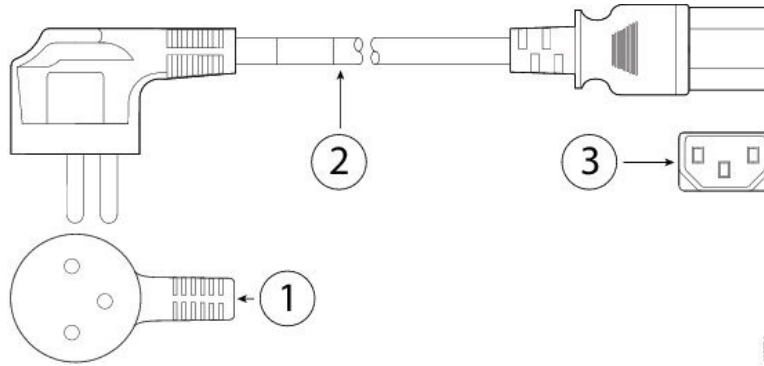

1	Plug: SI-32	2	Cord set rating: 10 A, 250 V
3	Connector: IEC 60320-C13		

Figure 25: Italy CAB-9K10A-IT

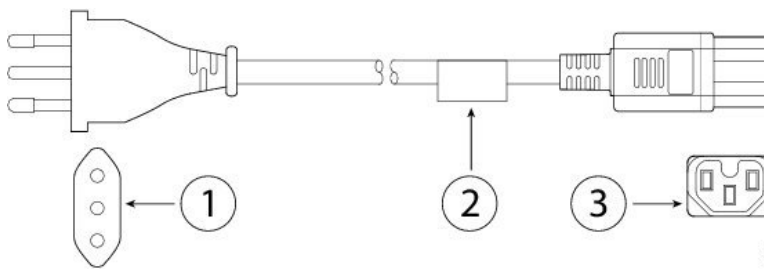

1	Plug: CEI 23-16/VII	2	Cord set rating: 10 A, 250 V
3	Connector: IEC 60320-C15		

Figure 26: Korea CAB-9K10A-KOR

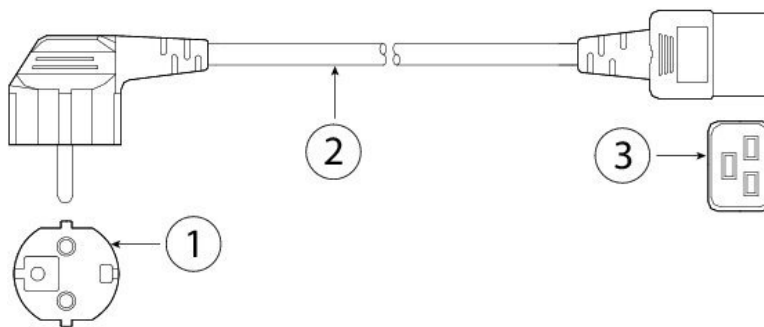

1	Plug: CEE 7/7	2	Cord set rating: 10 A, 250 V
3	Connector: IEC 60320-C19		

Figure 27: Japan CAB-L620P-C13-JPN

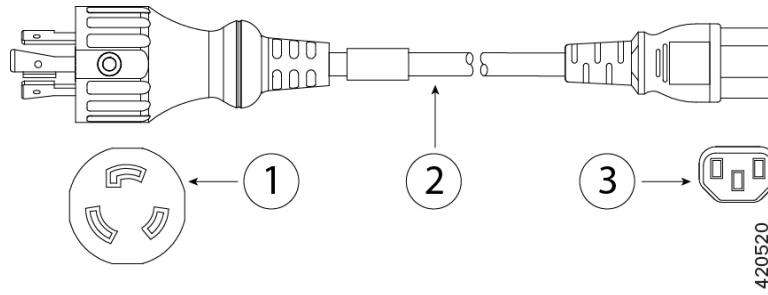

1	Plug: NEMA L6-20P	2	Cord set rating: 15 A, 250 V
3	Connector: IEC 60320-C13		

Figure 28: Japan CAB-TA-JP

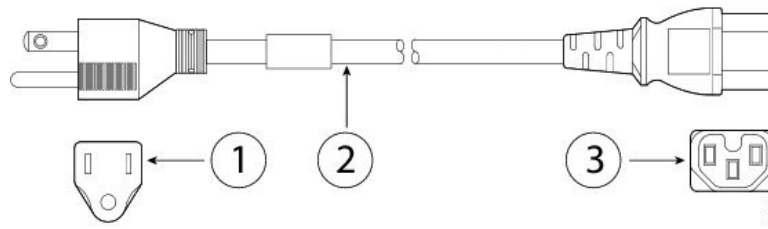

1	Plug: NEMA5-15P/JIS 8303	2	Cord set rating: 12 A, 125 V
3	Connector: IEC 60320-C15		

Figure 29: North America CAB-TA-NA

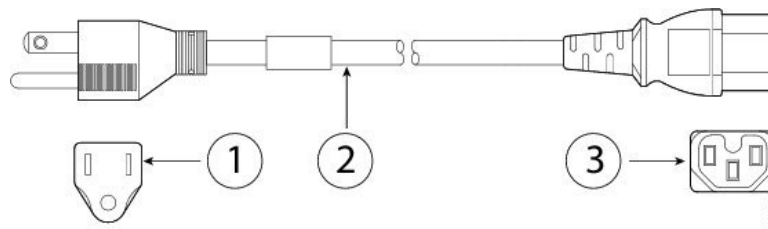

1	Plug: NEMA5-15P	2	Cord set rating: 12 A, 125 V
3	Connector: IEC 60320-C15		

Figure 30: Saudi Arabia ATA187PWRCORD-SAUD

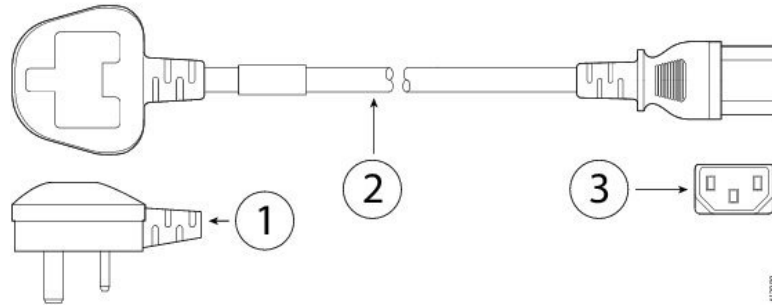

1	Plug: BS1363A/SS145	2	Cord set rating: 10 A, 250 V
3	Connector: IEC 60320-C13		

Figure 31: South Africa CAB-9K10A-SA

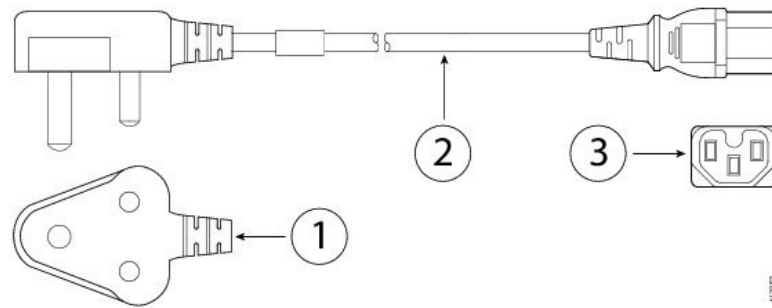

1	Plug: SABS 164	2	Cord set rating: 10 A, 250 V
3	Connector: IEC 60320-C15		

Figure 32: Switzerland CAB-9K10A-SW

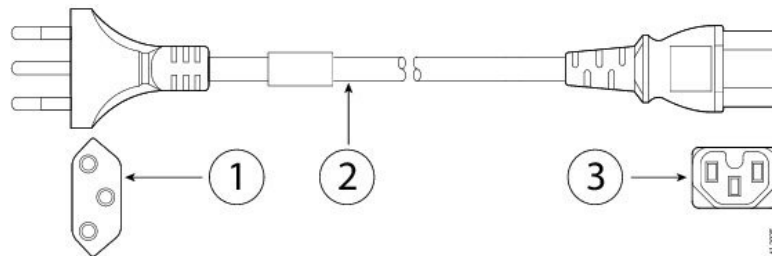

1	Plug: SEV 1011	2	Cord set rating: 10 A, 250 V
3	Connector: IEC 60320-C15		

Figure 33: Taiwan CAB-9K10A-TWN

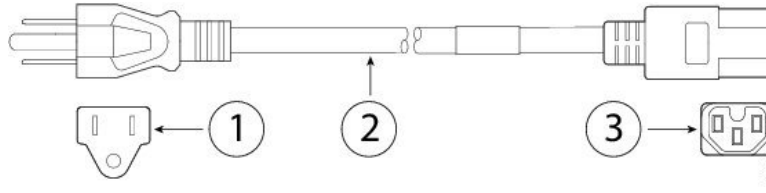

1	Plug: CNS10917-2	2	Cord set rating: 10 A, 125 V
3	Connector: IEC 60320-C15		

Figure 34: United Kingdom CP-PWR-CORD-UK

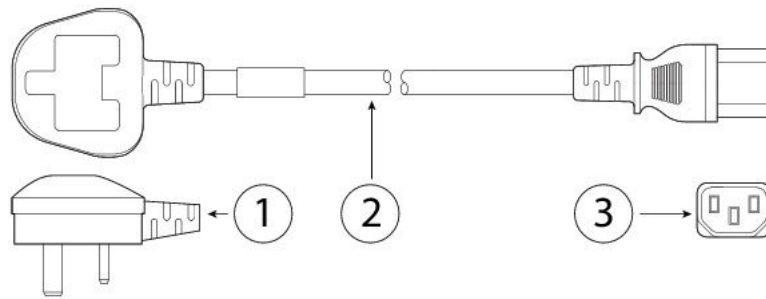

1	Plug: BS1363A/SS145	2	Cord set rating: 10 A, 250 V
3	Connector: IEC 60320-C13		

